

### Features:

- Digital Interface CAN
- MEMS Capacitive
- Triaxial
- Resolution: 20-bit
- Sample Rate: 1 to 4000 SPS (Customize)
- Measurement Range:  $\pm 2$  to  $\pm 40$  g (Customize)
- Frequency Range ( $\pm 5$  %): DC to 1000 Hz
- Aluminum Housing



### Applications:

- General Industrial Test & Measurement
- Condition Monitoring
- Robotics and Automation
- Tilt sensing
- Seismic imaging

Capacitive accelerometers are based on proven micro-electro-mechanical systems (MEMS) technology. These accelerometers are known for their reliability, long-term stability, and precision. MEMS technology enables the precise measurement of both static (DC) and continuous accelerations, allowing for the calculation of the velocity and displacement of moving objects.

The sensor is designed with three digital interfaces (**CAN**, USB, RS232) and can detect dynamic (AC) accelerations with amplitudes ranging from  $\pm 2$  g to  $\pm 40$  g. It has a speed of up to 4000 samples per second and a resolution close to  $4 \mu\text{g}$  in three axes. Users can choose the appropriate sensor based on their needs. The power supply voltage is flexible, ranging from 5 to 16 VDC. Triaxial accelerometers allow for quick and easy mounting.

### Marking:

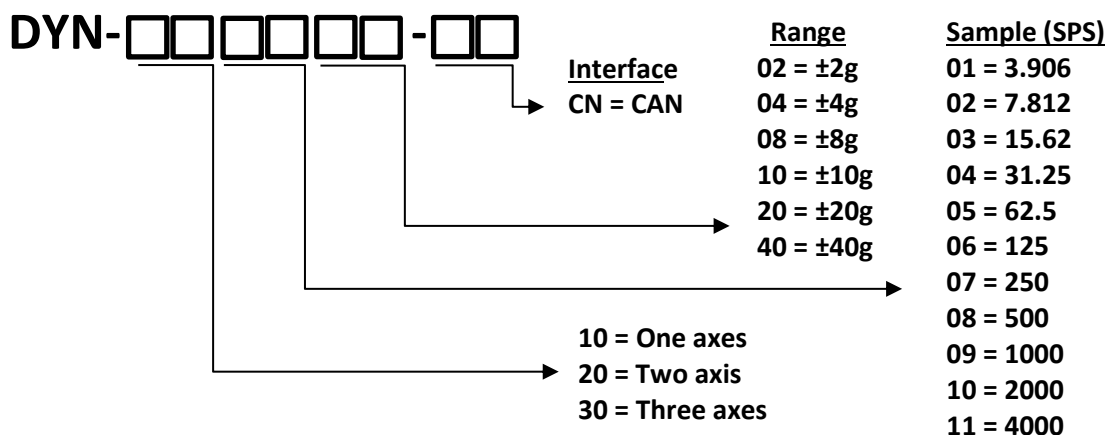

**Example:** DYN-301140-CN is a Triaxial, 4000 SPS,  $\pm 40$  g, Capacitive Accelerometer with CAN Interface.

## Specifications:

Full-scale acceleration	(g)	± 2	± 4	± 8	± 10	± 20	± 40
Scale Factor	(LSB/g)	256000	128000	64000	51200	25600	12800
Sensitivity	(µg/LSB)	3,90625	7,8125	15,625	0,195313	0,390625	0,78125
Sensitivity (Change/°C)	(%/°C)	±0.01	±0.01	±0.01	±0.01	±0.01	±0.01
0 g Offset	(mg)	±25	±25	±25	±125	±125	±125
Noise	(µg/√Hz)	25	25	25	75	85	90
Non-Linearity	(%)	0,1	0,8	1,6	0,1	0,5	1,3
Resolution (1 LSB)	(µg)	4	8	16	20	40	80

## Physical and Environmental:

Operating Voltage	5V - 16 V		
Operating Power/Current	1W/62.5 mA		
Operating Temperature	-40 °C to + 85 °C		
Shock Limit	5000 g		
Protection Level	IP 68		
Connector at Sensor (open ended)	Pin 1	NC	Shielding
	Pin 2	Red	5 - 16V
	Pin 3	Black	GND
	Pin 4	Yellow	CAN-High
	Pin 5	Green	CAN-Low
Mounting	Adhesive or screw holes		
Housing Material	Anodized Aluminum		
Weight (without cable)	80 g		

Sample per second (SPS)	Low-Pass Filter (Hz)
3,90625	0,97
7,8125	1,9
15,625	3,9
31,25	7,81
62,5	15,62
125	31,25
250	62,5
500	125
1000	250
2000	500
4000	1000

## Technical Drawings:

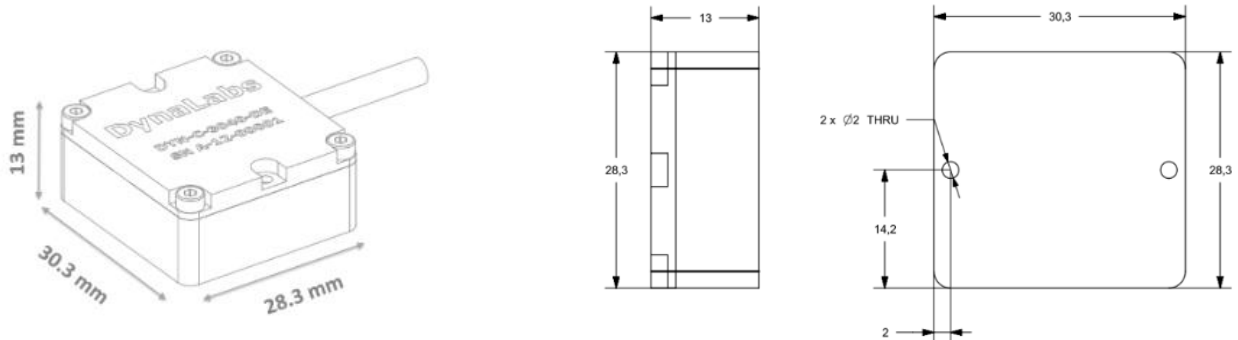

## Options:

- Customize Range
- Customize Frequency
- Customize Connector
- Customize Cable Length (5m standard cable)
- Customize Aluminum or Steel

## Quality:

All Dynalabs products are CE compliant.